

Bondurant Community Library Expansion
Contingency \$ 133,269.00

Base Bid												
Alternate 1 & 2												
Bid Package Contract Amount												

		Contingency	Allowance/Unit Price in BP	Owner Add	BP 5	Soft cost		Issued for Price	BP Price back	Story to Final	Issued Arch Review	Final to Library	Back from Owner
CR 001	Roller Shade Modification (PR-01)	\$ 827					Approved	x	x	x	x	x	x
CR 002	Delete Floor Boxes	\$ (214)					Approved	x	x	x	x	x	x
CR 003	Change Air Barrier to 0 degree temp	\$ 4,200					Approved	x	x	x	x	x	x
CR 004	Sunscreen Corner Knife Plates	\$ 410					Approved	x	x	x	x	x	x
CR 005	Added Stoop at Door 116.1	\$ 2,000					Approved	x	x	x	x	x	x
CR 006	Deduct Existing Screen Wall	\$ -					BP 06-1 for Pricing 1/19	x					
CR 007	Steel at Existing RTU	\$ 3,120					Approved	x	x	x	x	x	x
CR 008	Donor Plaque Credit	\$ (707)					Approved	x	x	x	x	x	x
CR 009	Steel Angles at Curtain Wall	\$ 155					Approved	x	x	x	x	x	x
CR 010	Temporary Masonry Enclosure at Area A	\$ 3,800					Approved	x	x	x	x	x	x
CR 010-1	Delete Temp Masonry Enclosure	\$ (1,900)					Approved	x	x	x	x	x	x
CR 011	Additional Coordination Labor	\$ 576					Approved	x	x	x	x	x	x
CR 012	Additional Paving at City Hall West Drive	\$ 61,561					Approved	x	x	x	x	x	x
CR 013	Move Vent Pipe & Duct Modification	\$ 2,700					To Library 4/28	x	x	x	x		
CR 014	Dumpster Pipe Bollards	\$ 2,693					To Library 4/28	x	x	x	x		
CR 015	Dumpster Gate Modifications	\$ 1,028					To Library 4/28	x	x	x	x		
CR 016	Cleaning Existing Brick & Additional Burnish Block Sealant	\$ 2,803					Approved	x	x	x	x	x	x
CR 017	Add Flashing at Windows at CMU	\$ 441					To Library 4/28	x	x	x	x		
CR 018	Copier Fax Machine Power & Data	\$ -					BP 26-1 for Pricing 4/23	x					
CR 019		\$ -											
CR 020		\$ -											

Sub Total \$ 83,493 \$ - \$ - \$ -

CCD - 001	Remove Tree Stump at South Addition	\$ 3,057					Approved	x	x	x	x	x	x
CCD - 002	Winter Concrete Protection	\$ -			\$ 2,380		Approved	x	x	x	x	x	x
CCD - 003	Temporary Electric Room	\$ -			\$ 1,920		Approved	x	x	x	x	x	x
CCD - 004	Additional Duct Work (Childrens Area), New Regulators & Temp Heat	\$ 1,201					Approved	x	x	x	x	x	x
CCD - 005	Insulation Add at Existing Screen wall Columns	\$ 2,300					Approved	x	x	x	x	x	x
CCD - 006	Temporary Sidewalk	\$ 2,700					To Library 4/28	x	x	x	x		
CCD - 007	Area C Temporary Enclosure at Clearstory Glass	\$ 750					Approved	x	x	x	x	x	x
CCD - 008	Additional Temporary Wall	\$ 968					To Library 4/28	x	x	x	x		
CCD - 009	Rock for Temp Access Removal	\$ 2,000					Placeholder						
CCD - 010	Floor Grinding and Floor Skim	\$ 1,516					Approved	x	x	x	x	x	x
CCD - 011	Floor Patching Allowance Deduct	\$ (5,000)					To Library 4/28	x	x	x	x		
CCD - 012	East Addition Sink Line	\$ 1,422					Approved	x	x	x	x	x	x
CCD - 013	Temp Heat Hookup & Thermostat Move	\$ 1,900					To Library 4/28	x	x	x	x		
CCD - 014	Demolition Allowance Deduct	\$ (6,000)					To Library 4/28	x	x	x	x		
CCD - 015	Patching of Gypsum Board @MEP Penetrations Allowance Deduct	\$ (6,000)					To Library 4/28	x	x	x	x		
CCD - 016	Temp Doors at Area C	\$ -					Placeholder						
CCD - 017		\$ -											
CCD - 018		\$ -											
CCD - 019		\$ -											
CCD - 020		\$ -											

CCD Totals \$ 814 \$ - \$ - \$ 4,300 \$ -

Total Contract includes CR/CCD \$ 84,307 \$ - \$ - \$ 4,300 \$ -

Total Contingency left \$ 48,962.20

Total BP Change Order Adds \$ 88,607

Construction Cost Todate \$ 2,753,987 3.22% percent of changes vs cost of work

Changes against Contingency

Changes against Contingency
 \$ 91,177 Approved Executed
 \$ (4,571) Approved Pending Signatures
 \$ 2,000 Story Review Pending - Budget amounts
 \$ 88,607
 Total Changes Approved
 \$ 91,177

Legend:	
Green	Approved
Purple	Library/Owner Court
Blue	FEH Design
Red	Story Court
Orange	Subcontractor Court
Yellow	Budget \$
Pink	Allowance



Change Request Summary

PROJECT: Bondurant Community Library Expansion CHANGE REQUEST NO.: **CR-013**

DATE: April 23, 2021

SUBJECT: Move Vent Pipe & Duct Modification

PROPOSED CHANGE DESCRIPTION

Per meeting with KCL Engineering on site, pricing to furnish material and labor to relocate existing vent pipe and rework duct transitions for RTU.

- Current location of vent pipe does not meet code for clearances.
- RTU needed to be repositioned to meet clearances.

SUMMARY OF COST BREAKDOWN:

<u>BP #</u>	<u>Description</u>	<u>Amount</u>
BP 22-1 Brockway	Move Vent Pipe & Duct Modification	\$2,699.81

Story Construction Co. Contractor	FEH Design Designer	Bondurant Library Board Owner
<input checked="" type="checkbox"/> Recommend Acceptance	<input checked="" type="checkbox"/> Recommend Acceptance	<input type="checkbox"/> Accepted
<input type="checkbox"/> Do Not Recommend Acceptance	<input type="checkbox"/> Do Not Recommend Acceptance	<input type="checkbox"/> Not Accepted
By: 	By: 	By: _____
Date: <u>4/24/21</u>	Date: <u>04-28-2021</u>	Date: _____

cc: Field
File

Breakdown Sheet

Labor, Material, & Equipment Contractor's Proposal



Date: 4.22.21

Title: CR-013

Description: Moving 4" Vent pipe that was within clearances of the Rooftop Units
Fabricate & Install Duct + Fittings for Revised RTU Layout
Replace 3 Existing Diffusers

Direct Employee Labor

Project Management @\$115.00		Hrs	\$	-
Plumber/Pipefitter @\$85.00	5.25	Hrs	\$	446.25
Sheet Metal Worker @\$82.00	12	Hrs	\$	984.00
CAD Tech @\$58.50		Hrs		

Equipment

--	--

Material

See attached material pricing	\$ 195.18
Duct Work (Lined Plenum Box + Transition)	\$ 417.54
Diffusers (x1) 24x24 & (x2) 12x12	\$ 270.00

Total Labor, Material & Equipment	\$ 2,312.97
15% Fee	\$ 346.95
Total Labor, Material & Equipment & Fee	\$ 2,659.92

Subcontractors

N/A	
5% Fee	\$ -
Total Subcontractors & Fee	\$ -

Other Costs

Travel and Subsistence	\$ -
Materials and Equipment Not Incorporated	\$ -
Rentals	\$ -
Taxes	
Permits and License Fees	\$ -
Utilities, Fuel and Facilities at Site	\$ -
Incidental Expenses	\$ -
Bond and/or Insurance Provisions	\$ 39.90
15% Fee	
Total Other Costs & Fee	\$ 39.90

Grand Total	\$ 2,699.81
--------------------	--------------------

Price valid 30 days from date shown above



Change Request Summary

PROJECT: **Bondurant Community Library Expansion**

CHANGE REQUEST NO.: **CR-014**

DATE: **April 9, 2021**

SUBJECT: **Dumpster Pipe Bollards**

PROPOSED CHANGE DESCRIPTION

Pricing to furnish and install three (3) pipe bollards at dumpster enclosure. Bollards to be 6" diameter, galvanized, extend 4 feet into the ground with 3'-6" ± above pavement. Bollards to be filled with concrete and rounded off at exposed top.

See attached detail for approximate location.

SUMMARY OF COST BREAKDOWN:

<u>BP #</u>	<u>Description</u>	<u>Amount</u>
BP 31-1 Absolute	Dumpster Enclosure Bollards	\$2,693.05

Story Construction Co. Contractor	FEH Design Designer	Bondurant Library Board Owner
<input checked="" type="checkbox"/> Recommend Acceptance	<input checked="" type="checkbox"/> Recommend Acceptance	<input type="checkbox"/> Accepted
<input type="checkbox"/> Do Not Recommend Acceptance	<input type="checkbox"/> Do Not Recommend Acceptance	<input type="checkbox"/> Not Accepted
By: 	By: 	By: _____
Date: <u>4/12/21</u>	Date: <u>04-28-2021</u>	Date: _____

cc: Field
File

Absolute Concrete Construction, Inc.

PO Box 148
505 1st Avenue
Slater, IA 50248

Phone: (515) 497-6137
Fax: (515) 497-6138



Change Order Proposal

Project: Bondurant Community Library Expansion

Date: 04-08-2021

To: Story Construction

Job Number: ACC20-016

Change Order Proposal Number: 04, Add Three Bollards

Description of Proposed Change:

CO for three additional bollards to be supplied and placed by Absolute Concrete. Top to be rounded off when filling. Painting of bollard and bollard sleeve excluded.

Item	Description	Quantity	Units	Unit Price	Amount
1	Galvanized, 6" Dia, 8' Length Pipe Bollards from DSM Steel	3	EA	\$ 255.00	\$ 765.00
2	Concrete Ready Mix to Set and Fill	2	CY	\$ 115.00	\$ 230.00
3	Man Hours to Dig, Set, Brace, Fill and Round Off Top	12	Hours	\$ 55.00	\$ 660.00
4	Mini Excavator to Dig for Bollard Placement	3	Hours	\$ 225.00	\$ 675.00
5	Formwork to brace bollards	1	LS	\$ 100.00	\$ 100.00
				Sub-Total:	\$ 2,430.00
				10 % Markup	\$ 243.00
				Increased Bond Cost	\$ 20.05
				Total:	\$ 2,693.05

Accepted:

Story Construction

Absolute Concrete Construction, Inc.

By: _____

By: _____

Date: _____

Date: _____

Des Moines Steel Co.

110 Clark Street
Des Moines, IA 50314-3407
Phone: 515-246-8004
Fax: 515-246-0102

Quotation

Quote Absolute Concrete
To: Po Box 148
Slater, IA 50244
United States

Quote Number:	21553	Contact:	
Quote Date:	04/08/2021	Expires:	05/08/2021
Customer:	ABSOLUTE CON	Inquiry:	
Salesman:	House Account	Terms:	NET 30 Days
Ship Via:	Pickup	Phone:	515-228-3030
		FAX:	515-228-3031

Thank you for the opportunity to submit this quote. All prices and terms are only valid for 24 hours due to steel pricing uncertainties from the date of this quote. There are no refunds on special orders, cuts and fabricated work that has been specked wrong by the customer.

<u>Item</u>	<u>Part Number</u> <u>Description</u>	<u>Revision</u>	<u>Quantity</u>	<u>Price</u>
1	PB6"GALV cut 3 @ 8'		24	\$31.21 /FT
2	CUTS OVER 4" W/H		3	\$2.50 /EA
			Total:	\$756.54

By Tharren Keith
Des Moines Steel Co.

10' PUBLIC UTILITY AND DRAINAGE EASEMENT

25' BUILDING SETBACK

30' BUILDING SETBACK

BUILDING EXPANSION

EXISTING BUILDING
FFE: 971.08

BUILDING EXPANSION

BUILDING EXPANSION

30' BUILDING SETBACK

PROTECT EXISTING COMMUNITY SIGN

5" SIDEWALK

HANDICAP SIGNS

6" PCC PAVING
SOUTH PARKING AREA

PERMEABLE PAVERS

5" SIDEWALK

6" PCC PAVING
EAST PARKING AREA

Approximate bollard locations

EXISTING CURB LINE

SOUTH PARKING ENTRANCE

Point #	Raw Description	Elevation	Northing	Easting
70500	cp prp 3/4 in rb	970.600	620706.8720	1651010.2010
70499	cp 102 x cut	969.390	620483.7180	1651048.7180
1307	bm 4 city brass disc	969.428	620512.2630	1650906.5340
70003	cp	973.410	620894.9000	1650493.5800
70000	cp	970.490	620651.9900	1650793.3600
70001	cp	969.050	620481.6470	1650824.3570
70002	cp	969.070	620490.1450	1650502.7010

NOTES:
UNLESS OTHERWISE NOTED ALL CONSTRUCTION WILL
CONFORM TO IOWA SUDAS VER. 2020

AD-1
- PLACED SURVEY CONTROL TABLE



FEH DESIGN
 DES MOINES, IA (515) 282-2000
 DUBUQUE, IA (563) 563-4600
 CCNONKOWOC, WI (262) 966-2055
 © FEH DESIGN

VEENSTRA & KIMM, INC.
 3000 Westown Parkway
 West Des Moines, Iowa
 50266-1320
 515.225.8000
 515.225.7448 (FAX)

SHEET TITLE
SITE PLAN

PROJECT TITLE
City of Bondurant
**BONDURANT COMMUNITY LIBRARY
EXPANSION**
104 2nd St. NE, Bondurant, IA 50035

DATE ISSUED 08-31-2020
AD-1 09-11-2020

PROJECT NUMBER
2018231.02

SHEET

C1



Change Request Summary

PROJECT: **Bondurant Community Library Expansion**

CHANGE REQUEST NO.: **CR-015**

DATE: **April 9, 2021**

SUBJECT: **Dumpster Gate Modification**

PROPOSED CHANGE DESCRIPTION

Pricing to modify current 8"x8" HSS tubing for dumpster gate posts to receive base plates for anchoring to concrete footings at dumpster location. Four (4) posts in total to be modified.

See attached sketch for base plate details.

SUMMARY OF COST BREAKDOWN:

<u>BP #</u>	<u>Description</u>	<u>Amount</u>
BP 06-1 Grabau	Dumpster Gate Modification	\$1,028.16

Story Construction Co. Contractor	FEH Design Designer	Bondurant Library Board Owner
<input checked="" type="checkbox"/> Recommend Acceptance	<input checked="" type="checkbox"/> Recommend Acceptance	<input type="checkbox"/> Accepted
<input type="checkbox"/> Do Not Recommend Acceptance	<input type="checkbox"/> Do Not Recommend Acceptance	<input type="checkbox"/> Not Accepted
By: 	By: 	By: _____
Date: <u>4/12/21</u>	Date: <u>04-28-2021</u>	Date: _____

cc: Field
File



**R.H. GRABAU CONSTRUCTION, INC.
GENERAL CONTRACTOR**

P.O. Box 99 • Boone, IA 50036
515-432-6935 • FAX 515-432-9639 • www.grabauconst.com

Since 1946

CHANGE PROPOSAL

CR-015

APRIL 7, 2021

STORY CONSTRUCTION
2810 WAKEFIELD CIRCLE
AMES, IA 50010

Attn: RICHARD VAN

Re: BONDURANT COMMUNITY LIBRARY – BID PACKAGE 06-1.

Richard,

The following is the cost for CR-015. This pertains to the following:

- **Modifications to dumpster gate. See attached for cost breakdown.**

This will be an additional cost of \$1,028.16.

Very truly yours,

R. H. GRABAU CONSTRUCTION, INC.

Eric Hammer

Date: 4-7-21



ITEM:	QUANT.	UNIT.	\$	HOURS	LABOR	MATERIAL	TOTAL:
			80		0	\$	-
			80		0	\$	-
			80		0	\$	-
			80		0	\$	-
			80		0	\$	-
			80		0	\$	-
			80		0	\$	-
			80		0	\$	-
			80		0	\$	-
			80		0	\$	-
			80		0	\$	-
			80		0	\$	-
			80		0	\$	-
			80		0	\$	-
			80		0	\$	-
			80		0	\$	-
			80		0	\$	-
			80		0	\$	-
			80		0	\$	-
			80		0	\$	-
			80		0	\$	-
			80		0	\$	-
			80		0	\$	-

Small or Rental Tools:
Equipment:
Clean Up:
Material Handling:
OSHA Safety
General Conditions
Subtotal Self-Performed: \$ -

SUBCONTRACTORS:	QUANT.	UNIT.	\$
Mid States Steel			\$ -
See attached for cost breakdown	1	960	\$ 960.00
			\$ -
			\$ -
<i>*No additional cost for labor to Instoll</i>			\$ -
			\$ -
			\$ -
			\$ -

Number of days added _____

0% TAX	\$ -
Subtotal Subcontractors:	\$ 960.00
10% OH on self	\$ -
5% Profit on self	\$ -
5% OH on subs	\$ 48.00
0% Profit on subs	\$ -
2% Bond	\$ 20.16

TOTAL = \$ 1,028.16



2515 Industrial Park Road
Boone, IA 50036-3045
Phone (515) 432-1646

EMPLOYEE OWNED

Attention: Eric Hammer

Project: <u>Bondurant Library Expansion</u>	Location: <u>Bondurant, Iowa</u>	Job # <u>6261</u>
Customer: <u>R. H. Grabau Construction, Inc.</u>	Contact: <u>Eric Hammer</u>	C.O. # <u>4</u>
Telephone # <u>515-432-6935 Ext. 14</u>	Email <u>ehammer64@yahoo.com</u>	Date: <u>04/07/21</u>

Per CR-015:

Modify (4) dumpster gate posts (MSS picked up from job site 04/07/21):

Cut galvanized posts to required length, shop weld on nongalvanized base plate,

(16) 1/2 dia. threaded rods x 8" with nuts & washers.

(epoxy by others)For the sum of: 960.00

Sales tax exempt

*****This is priced with customer pick up of material upon completion****NOTE: Mid-States Steel will not proceed without a contract change order.**

Original Contract Amount	86,454.00
Approved Change Orders	<u>320.00</u>
Current Contract Amount	86,774.00

Request for Change Order #2 dated 01/28/21	2,370.00 Pending
Request for Change Order #4 dated 04/07/21	960.00

If accepted, new contract amount	90,104.00
----------------------------------	------------------

All other terms and conditions of the original purchase order will remain unchanged.

Accepted by: _____ Date: _____ Proposal by: Jeff Drake Date: 04/07/21



Change Request

PROJECT: **Bondurant Community Library Expansion**

CHANGE REQUEST NO.: **CR-015**

DATE: **April 6, 2021**

COPIES TO: **BP 06-1 RH Grabau Construction**

SUBJECT: **Dumpster Gate Modification**

PROPOSED CHANGE - Please review the following proposed change to the Contract Documents and determine the impact on your work:

1. Provide pricing to modify current 8"x8" HSS tubing for dumpster gate posts to receive base plates for anchoring to concrete footings at dumpster location. Four (4) posts in total to be modified.

See attached sketch for base plate details.

CONTRACTOR PROPOSAL - List breakdown of costs for the proposed change in the space below. Attach breakdown if additional space is required. Include any comments or remarks and advise if proposed change affects contract time. If this is a no cost change, please note in space below. Execute, date, and respond no later than April 7, 2021.

Return to Story Construction Co., via submittal exchange.

<u>Contractor</u>	<u>Description</u>	<u>Amount</u>
BP 06-1 Grabau	Dumpster Gate Modification	\$ _____
	Total Change	\$ _____

Signature: _____

Date: _____

Attachments
cc: Field
File

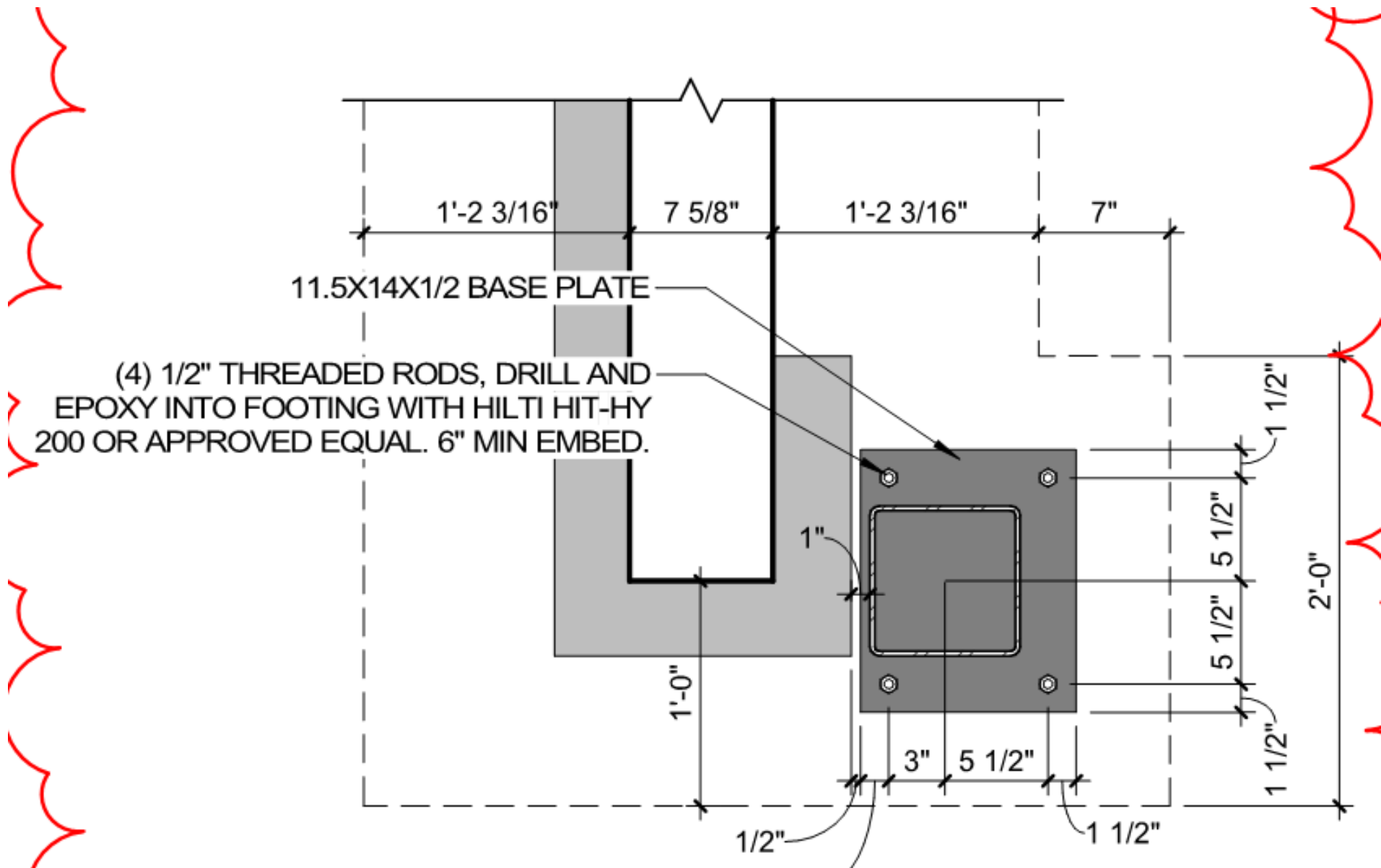



Change Request Summary

PROJECT: **Bondurant Community Library Expansion**

CHANGE REQUEST NO.: CR-017

DATE: **April, 9 2021**

SUBJECT: **Add Flashing at Windows**

PROPOSED CHANGE DESCRIPTION

Per the reviewed shop drawings, Architect has instructed to add sheet metal flashing at North windows. Price to furnish and install window flashing at windows.

See attached drawing for window locations.

SUMMARY OF COST BREAKDOWN:

<u>BP #</u>	<u>Description</u>	<u>Amount</u>
BP 08-1 MAGS	Add Flashing at Windows	\$441.00

Story Construction Co. Contractor	FEH Design Designer	Bondurant Library Board Owner
<input checked="" type="checkbox"/> Recommend Acceptance	<input checked="" type="checkbox"/> Recommend Acceptance	<input type="checkbox"/> Accepted
<input type="checkbox"/> Do Not Recommend Acceptance	<input type="checkbox"/> Do Not Recommend Acceptance	<input type="checkbox"/> Not Accepted
By: 	By: 	By: _____
Date: <u>4/12/21</u>	Date: <u>04-28-2021</u>	Date: _____

cc: Field
File



Change Request

PROJECT: **Bondurant Community Library Expansion**

CHANGE REQUEST NO.: **CR-017**

DATE: **April 7, 2021**

COPIES TO: **BP 08-1 Mid-American Glazing Systems**

SUBJECT: **Add Flashing at Windows**

PROPOSED CHANGE - Please review the following proposed change to the Contract Documents and determine the impact on your work:

1. Per the reviewed shop drawings, Architect has instructed to add sheet metal flashing at North windows. Provide price to furnish and install window flashing at windows.

See attached drawing for window locations.

CONTRACTOR PROPOSAL - List breakdown of costs for the proposed change in the space below. Attach breakdown if additional space is required. Include any comments or remarks and advise if proposed change affects contract time. If this is a no cost change, please note in space below. Execute, date, and respond no later than **April 9, 2021**.

Return to Story Construction Co., via submittal exchange.

<u>Contractor</u>	<u>Description</u>	<u>Amount</u>
BP 08-1 MAGS	Add Flashing at Windows	\$ <u>441.00</u>
	Total Change	\$ <u>441.00</u>

Signature: Mike Carlson

Date: 04-09-21

Attachments
cc: Field
File

2810 Wakefield Circle, Ames, IA 50010 | phone 515.232.4358 | fax 515.232.0599 | www.storycon.com

GENERAL CONTRACTING | DESIGN+BUILD | CONSTRUCTION MANAGEMENT

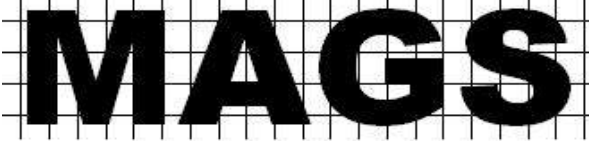

CHANGE ORDER REQUEST

1

Mid-American Glazing Systems
3750 W. River Dr.
Davenport, IA 52802
ph. 563) 383-6001

OWNER OR CONTRACTOR

Story Construction
2810 Wakefield Circle
Ames, IA 50010

PROJECT

Bondurant Community Library Expans
104 NE 2nd street
Bondurant, IA 50035

PROJECT #

0

CONTRACT DATE

October 6, 2020

DATE ISSUED

March 30, 2021

Description of change order request:

Add break metal to sills of storefront W2b (3) & W1 (1). North wall

TOTAL CHANGES \$441.00

Contract Details

Original Contract Sum	\$124,000.00	
Net Change By Previous Change Orders.....	\$0.00	
Contract Sum To Date	\$124,000.00	*See below
Amount of this Change Order	\$441.00	
New Contract Value Including This Change Order	\$124,441.00	*See below

Please issue a change order to Mid American Glazing Systems, Inc. Reflecting the above described work and values within (5) working days.

By: _____
Title: _____
Date: _____

* Contract sum may not reflect all change orders submitted

1 SILL DETAIL

REF NO: 18
 REF SHT: A3.2
 SCALE: 6" = 1'-0"

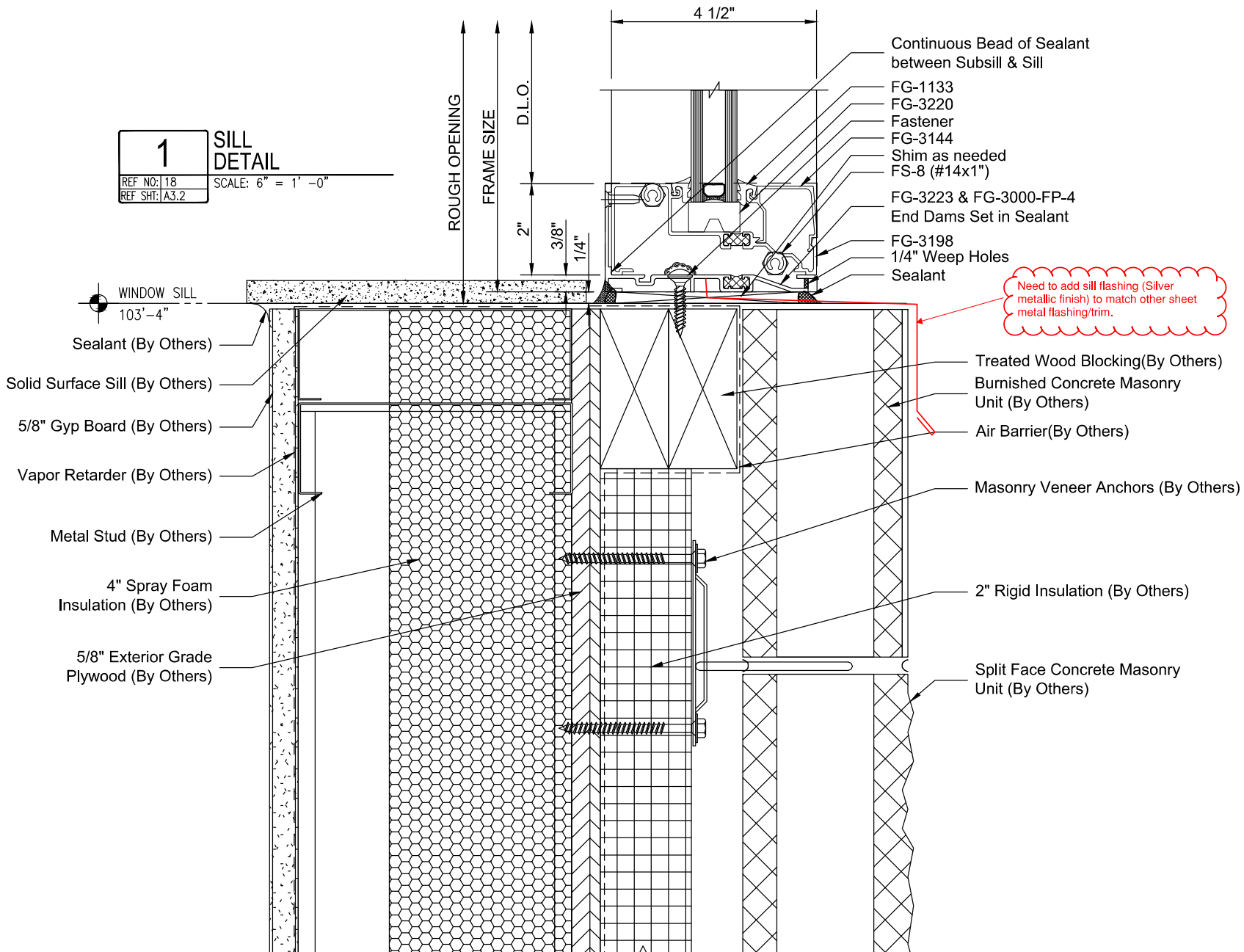

Need to add sill flashing (Silver metallic finish) to match other sheet metal flashing/trim.

Bondurant Community Library Expansion

MID-AMERICAN
 GLAZING SYSTEMS

3750 West River Drive
 Davenport, IA 52802
 563-383-6001 (phone)
 563-383-0889 (fax)

MATERIALS BY:
Oldcastle

PROJECT:
 Bondurant Community Library Expansion
 104 2nd Street, NE
 Bondurant, IA 50035
 Telephone: 515-967-4790
 Project # 2018231.02

ARCHITECT:
 FEH Design
 604 East Grand Avenue
 Des Moines, IA 50309
 Telephone: 515-268-2000

CONTRACTOR:
 Slory Construction Co.
 2810 Wakefield Circle
 Ames, IA 50010
 Telephone: 515-232-4358
 Facsimile: 515-232-0599

DATE: 11/24/2020	SHEET: 3.03
Revision#	Drawn By: AE
SCALE: 6" = 1'-0"	

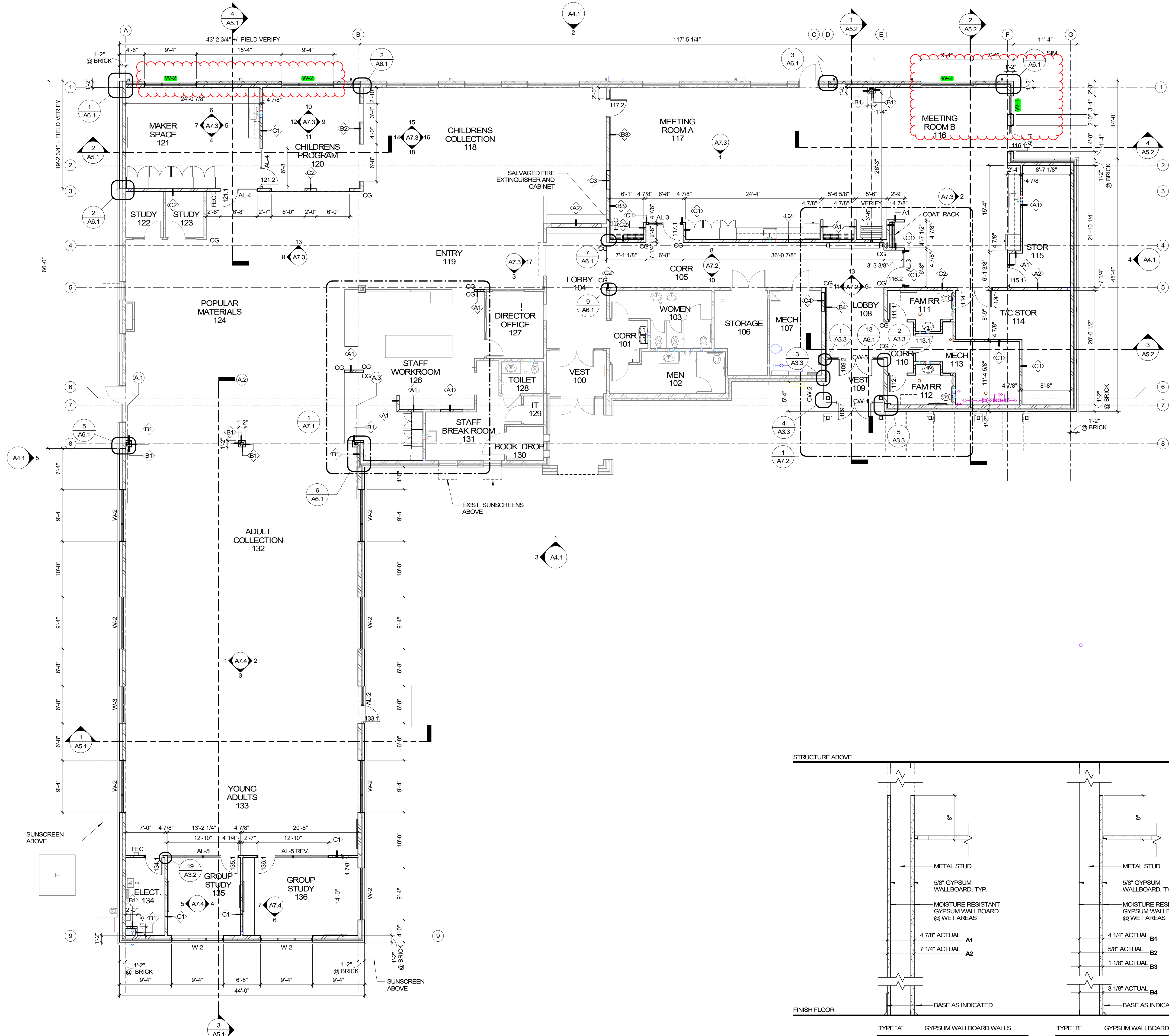

1 MAIN FLOOR PLAN
SCALE: 1/8" = 1'-0"

MATERIAL LEGEND

BATT INSULATION	[Pattern]	METAL STUDS	[Pattern]
BRICK	[Pattern]	PLYWOOD	[Pattern]
CONCRETE BLOCK	[Pattern]	RIGID INSULATION	[Pattern]
GRANULAR FILL	[Pattern]	GROUT	[Pattern]
CONCRETE	[Pattern]	STEEL	[Pattern]
EARTH	[Pattern]	STONE	[Pattern]
EIFS	[Pattern]	WOOD	[Pattern]
GYPSUM WALLBOARD	[Pattern]		

ARCHITECTURAL GENERAL NOTES

- THESE CONSTRUCTION DRAWING SHEETS ARE TO BE READ IN CONJUNCTION WITH THE PROJECT MANUAL.
- WHEN DRAWINGS AND PROJECT MANUAL CONFLICT, BIDDER SHALL REQUEST WRITTEN CLARIFICATION FROM THE ARCHITECT PRIOR TO BIDDING. IF CLARIFICATION IS NOT OBTAINED PRIOR TO BIDDING, THE FOLLOWING SHALL BE USED TO DETERMINE SCOPE OF BID MATERIAL SIZE AND QUANTITY SHALL BE DETERMINED BY DRAWINGS, QUALITY IS DETERMINED BY PROJECT MANUAL. FINAL DETERMINATION SHALL BE BY THE ARCHITECT OR ENGINEER PRIOR TO CONSTRUCTION OR FABRICATION.
- ERRORS ARE TO BE REPORTED IMMEDIATELY TO THE ARCHITECT.
- STRUCTURAL DRAWINGS GOVERN FOR SIZES, SPACING, AND CONNECTIONS OF ALL STRUCTURAL MATERIALS AND MEMBERS. IN THE CASE OF DISCREPANCIES, CONSULT WITH THE ARCHITECT/ENGINEER BEFORE COMMENCEMENT OF WORK.
- INSTALL VAPOR BARRIERS DIRECTLY BELOW ALL CONCRETE INTERIOR SLAB-ON-GRADE.
- THE CONTRACTOR SHALL ARRANGE FOR THE PREMISES TO BE MAINTAINED IN AN ORDERLY MANNER THROUGHOUT THE COURSE OF THE JOB. MAINTAIN CLEANLINESS THROUGHOUT - DO NOT BLOCK EXITS, ENTRANCES, LOBBIES, CORRIDORS, ETC. PROTECT AREA FROM DAMAGE WHICH MAY OCCUR FROM DEMOLITION DUST, WATER, ETC. PROVIDE AND MAINTAIN TEMPORARY BARRICADES, CLOSURE WALLS, ETC. AS REQUIRED TO PROTECT THE PUBLIC DURING THE PERIOD OF CONSTRUCTION. DAMAGE OF EXISTING STRUCTURES AND EQUIPMENT SHALL BE REPAIRED OR REPLACED TO THE SATISFACTION OF THE OWNER AT THE EXPENSE OF THE CONTRACTOR.
- THE CONTRACTOR SHALL BE RESPONSIBLE FOR REMOVING ALL LEFT-OVER MATERIALS, DEBRIS, TOOLS, AND EQUIPMENT INVOLVED AT THE CONCLUSION OF THE INSTALLATION. THE CONTRACTOR SHALL LEAVE ALL AREAS CLEAN. ALL FIXTURES AND REUSABLE MATERIALS TO BE REMOVED ARE TO BE STORED OR DISPOSED OF AS PER OWNER'S INSTRUCTIONS.
- CONTRACTOR SHALL TAKE PRECAUTIONS TO PREVENT WORKERS FROM INJURY OR EXPOSURE TO DANGEROUS MATERIALS DURING THE WORK BY THE CONTRACTOR. AS PER OSHA REGULATIONS AND FIRE-WATCH AS PER THE SUPPLEMENTAL CONDITIONS IN THE PROJECT MANUAL.
- DO NOT SCALE DRAWINGS. NOTIFY ARCHITECT / ENGINEER IF ADDITIONAL DIMENSIONS ARE REQUIRED OR DISCREPANCIES DISCOVERED.
- ALL EXISTING FACILITY DIMENSIONS ARE TO BE VERIFIED ON SITE.
- CONTRACTOR TO VERIFY EXISTING CONDITIONS AND DIMENSIONS PRIOR TO SHOP DRAWING APPROVAL AND BEFORE CONSTRUCTION. SEE PROJECT MANUAL WHERE FIELD VERIFICATION CANNOT BE OBTAINED PRIOR TO SHOP DRAWING APPROVAL.
- DIMENSIONS ARE ACTUAL. DIMENSIONS FOR MASONRY WALLS ARE GIVEN FROM FACE TO FACE OF WALL. DIMENSIONS FOR STUD WALL IS TO FACE OF FINISH WALL.
- SEE TYPICAL MOUNTING HEIGHTS FOR EQUIPMENT AND FIXTURES.
- FOR ADDITIONAL PLAN INFORMATION REFER TO PARTIAL ENLARGED PLANS OR DETAILS AS NOTED ON THE DRAWINGS.
- PROVIDE FINISHED END OR FRONT PANELS ON ALL SURFACES OF CASEWORK THAT ARE EXPOSED TO VIEW.

WALL AND PARTITION NOTES

- ALL WALL PARTITIONS ARE FULL HEIGHT U.O.N. SEE TYPICAL WALL TYPES.
- AT TOP AND BOTTOM OF WALL, PROVIDE ACOUSTIC SEALANT AT WALLS WITH SOUND INSULATION.
- HOLD GYPSUM BOARD 1/2" OFF ALL SLABS AND STRUCTURE.
- PROVIDE SOLID BLOCKING BEHIND WALL, MOUNTED GRAB BARS, RESTROOM ACCESSORIES, EQUIPMENT, CABINETS, SHELVES AND SIMILAR ITEMS ON GYPSUM BOARD PARTITIONS.
- CONTROL JOINTS NOT TO EXCEED 30" SPACING IN ANY DIRECTION FOR GYPSUM BOARD WALLS. WHERE CONTROL JOINTS ARE NOT DIMENSIONED, LOCATE JOINTS AT INTERSECTIONS OF INTERIOR WALLS AND COORDINATE WITH ARCHITECT. IF CONTROL JOINTS ARE NOT INDICATED ON THE FLOOR PLANS, CEILING PLANS, EXTERIOR ELEVATIONS, OR INTERIOR ELEVATIONS, OBTAIN APPROVAL OF LOCATIONS FROM THE ARCHITECT PRIOR TO CONSTRUCTION. SEE TYPICAL CONTROL JOINT DETAILS.

FLOOR PLAN LEGEND

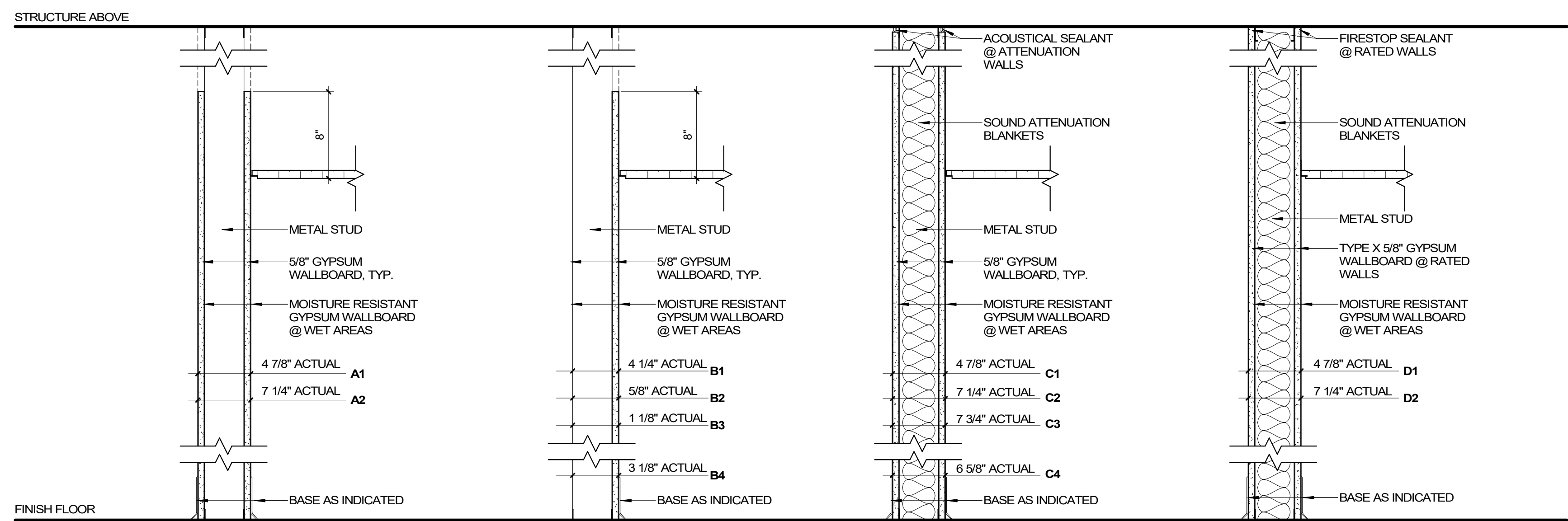
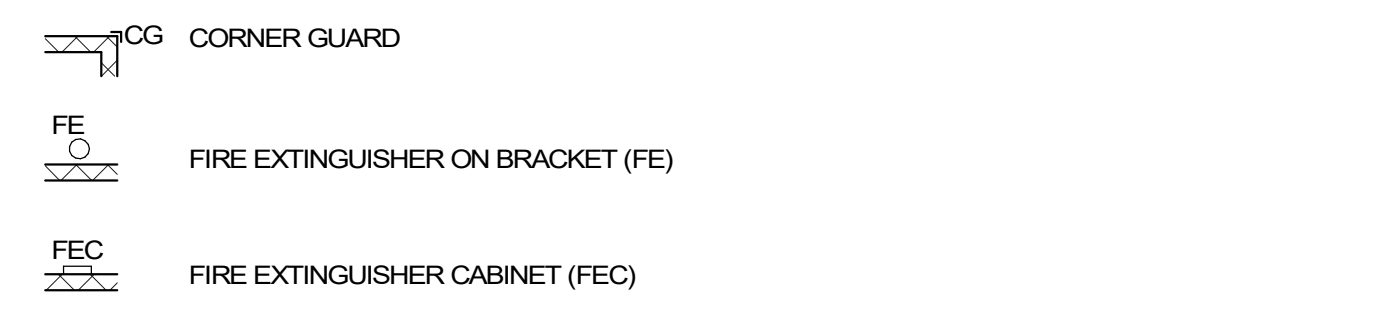

TYPE "A"	GYPSUM WALLBOARD WALLS	TYPE "B"	GYPSUM WALLBOARD WALLS	TYPE "C"	GYPSUM WALLBOARD SOUND ATTENUATION WALLS	TYPE "D"	GYPSUM WALLBOARD SOUND ATTENUATION / FIRE WALLS
A1-	3 5/8" METAL STUD WITH 1 LAYER 5/8" GYPSUM WALLBOARD ON EACH SIDE (4 7/8")	B1-	3 5/8" METAL STUD WITH 1 LAYER 5/8" GYPSUM WALLBOARD ON ONE SIDE (4 1/4")	C1-	3 5/8" METAL STUD WITH 1 LAYER 5/8" GYPSUM WALLBOARD ON EACH SIDE (4 7/8")	D1-	3 5/8" METAL STUD WITH 1 LAYER 5/8" GYPSUM WALLBOARD ON EACH SIDE (4 7/8")
A2-	6" METAL STUD WITH 1 LAYER 5/8" GYPSUM WALLBOARD ON EACH SIDE (7 1/4")	B2-	1 LAYER 5/8" GYPSUM WALLBOARD OVER PLYWOOD SHEATHING ON EXISTING WALL FOR FULL HEIGHT OF WALL (5/8")	C2-	6" METAL STUD WITH 1 LAYER 5/8" GYPSUM WALLBOARD ON EACH SIDE (7 1/4")	C3-	6" METAL STUD WITH 1 LAYER 1/2" PLYWOOD ON EAST FACE ONLY AND 1 LAYER 5/8" GYPSUM WALLBOARD ON EACH SIDE (7 3/4")
	USE MOISTURE RESISTANT GYPSUM WALLBOARD AT TOILETS AND OTHER WET AREAS.	B3-	1 1/2" PLYWOOD SHEATHING WITH 5/8" GYPSUM WALLBOARD FOR FULL HEIGHT OF WALL OVER EXISTING 6" FRAMING - SEE STRUCTURAL FOR ADDITIONAL NOTES. B3 WALL SHOULD HAVE SOUND BATT INSULATION INSTALLED. (1 1/8")	C4-	SEE STRUCTURAL FOR ADDITIONAL NOTES	D2-	6" METAL STUD WITH 1 LAYER 5/8" GYPSUM WALLBOARD ON EACH SIDE (6 5/8")
		B4-	2 1/2" METAL STUD WITH 1 LAYER 5/8" GYPSUM WALLBOARD ON ONE SIDE (3 1/8")				
			USE MOISTURE RESISTANT GYPSUM WALLBOARD AT TOILETS AND OTHER WET AREAS.				

WALL TYPES
SCALE: 1 1/2" = 1'-0"

FEH DESIGN

DUBLUQUE, IA (515) 252-3889
DES MOINES, IA (515) 288-2000
SIOUX CITY, IA (712) 252-3889

OCCONOMOUC, VT (862) 988-2055
© FEH DESIGN.COM

PROJECT TITLE: City of Bondurant
SHEET TITLE: FLOOR PLAN
PROJECT NUMBER: 2018231.02
DATE ISSUED: 08-31-2020
REV. NO. DATE
SHEET: A1.1



CONSTRUCTION CHANGE DIRECTIVE NO. CCD-006

Date: March 9, 2021
To: BP 31-1 Absolute Concrete Construction
Subject: Temporary Sidewalk at South Addition
Re: **Bondurant Community Library Expansion**
City of Bondurant
Bondurant, Iowa

The following change in the contract document is approved and the work is authorized to proceed accordingly. Determine and submit final costs and time adjustments (if any) in accordance with the conditions of the contract. **Document and confirm quantities with the Construction Manager on a daily basis.** This change will be incorporated in a subsequent change order.

DESCRIPTION:

Furnish labor, material, and equipment to install temporary sidewalk at East door of South Addition for access in and out of building. Contractor and CM to agree on an acceptable width of sidewalk prior to placement.

See attached drawing for sidewalk layout.

Contractor

BP 31-1 Absolute Concrete	Temp Sidewalk	\$ 2,700.00
---------------------------	---------------	-------------

Issued by Story Construction Co.

Clint Jensen
Project Manager

Authorized by:

City of Bondurant

cc: Richard Van
Charlie Harris
Janie Bates

Absolute Concrete Construction, Inc.PO Box 148
505 1st Avenue
Slater, IA 50248**Phone:** (515) 497-6137
Fax: (515) 497-6138

Change Order Proposal**Project:** Bondurant Community Library Expansion**Date:** 4-19-21**To:** Story Construction**Job Number:** ACC20-016**Change Order Proposal Number:** 03, Temp Walk / Site Grading

Description of Proposed Change:

CO For T&M Temp Walk and Site Grading on 4-1-21 and 4-2-21 by Absolute Concrete.

Item	Description	Quantity	Units	Unit Price	Amount
1	Man Hours Foreman	6.5	Hour	\$ 67.50	\$ 438.75
2	Man Hours Laborer	23.5	Hour	\$ 57.50	\$ 1,351.25
3	Equipment Hours Skid Loader	2	Hour	\$ 125.00	\$ 250.00
4	C4WRC20 from Manatts	4	CY	\$ 115.00	\$ 460.00
5	Formwork, Expansion, Misc Mats	1	LS	\$ 200.00	\$ 200.00
				Sub-Total:	\$ 2,700.00
				10% Markup	\$ 270.00
				Increased Bond Cost	\$ 22.28
				Total:	\$ 2,700.00

Accepted:**Story Construction****Absolute Concrete Construction, Inc.****By:** _____**By:** _____**Date:** _____**Date:** _____

BUILDING EXPANSION

EXISTING BUILDING
FFE: 971.08

971

971

70353

X 971.08

70489

70.84

70.78
Approximate temp
sidewalk location

BUILDING EXPANSION

70.85

70.75

70.72

70.69

970.5

70.23

69.6

69.73 GT

70.79

70.53

70.51

70.47

70.09 GT

70.02 GT

70.22 GT

970.0

969.5

69.22

970.0

970.5

970.0

69.5

SW-501

969.0

69.49

69.85

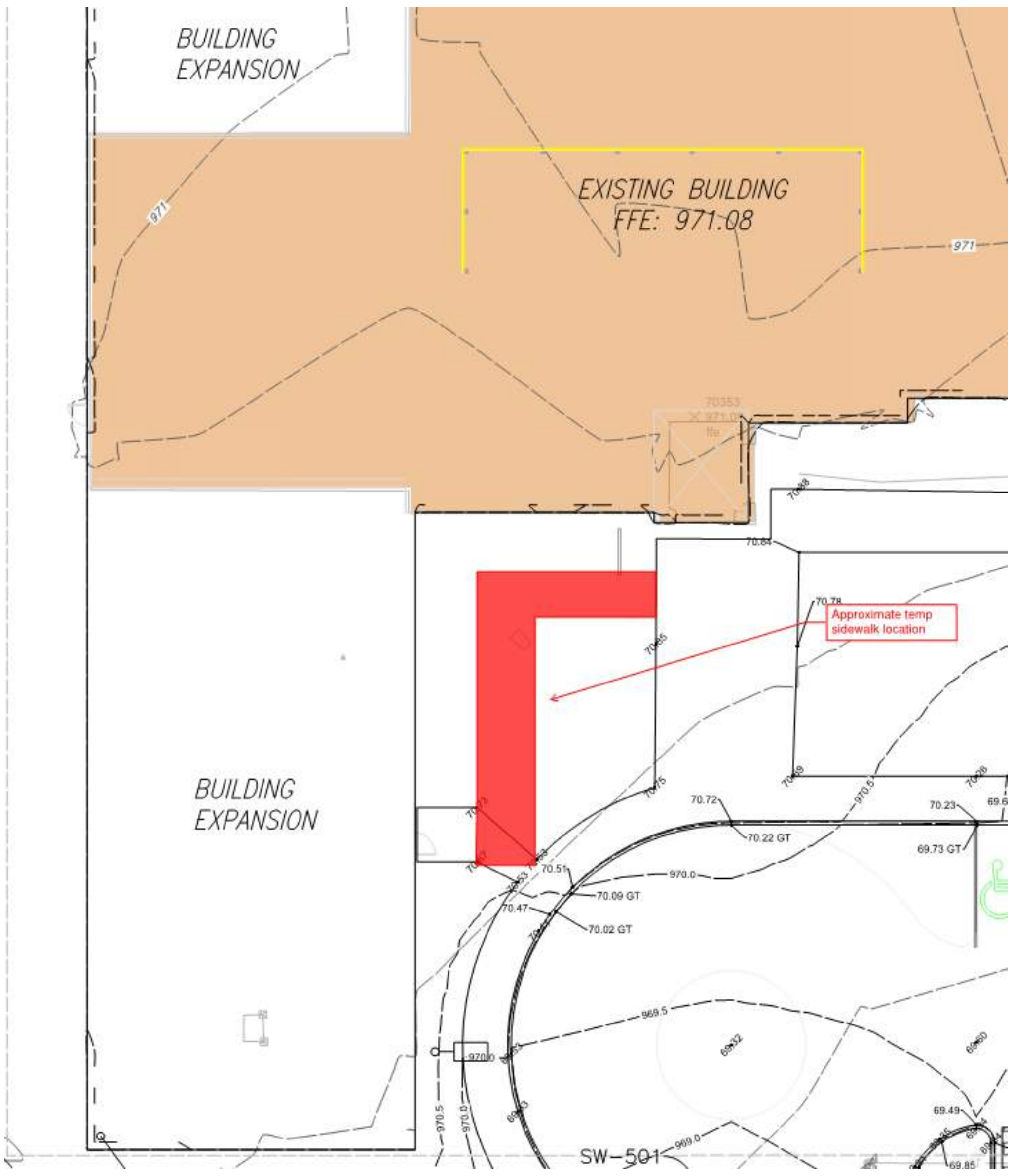



CONSTRUCTION CHANGE DIRECTIVE NO. CCD-008

Date: March 9, 2021
To: BP 06-1 RH Grabau Construction Inc
Subject: Additional Temporary Wall
Re: **Bondurant Community Library Expansion**
City of Bondurant
Bondurant, Iowa

The following change in the contract document is approved and the work is authorized to proceed accordingly. Determine and submit final costs and time adjustments (if any) in accordance with the conditions of the contract. **Document and confirm quantities with the Construction Manager on a daily basis.** This change will be incorporated in a subsequent change order.

DESCRIPTION:

Continue temporary wall as shown in attached sketch to provide division between continuing work and Library operations. Utilize materials onsite that were used for previous temporary partition walls.

Contractor

BP 06-1 RH Grabau	Temp Wall	\$ 967.73
-------------------	-----------	-----------

Issued by Story Construction Co.

Clint Jensen
Project Manager

Authorized by:

City of Bondurant

cc: Richard Van
Charlie Harris
Janie Bates



**R.H. GRABAU CONSTRUCTION, INC.
GENERAL CONTRACTOR**

P.O. Box 99 • Boone, IA 50036
515-432-6935 • FAX 515-432-9639 • www.grabauconst.com

Since 1946

CHANGE PROPOSAL

CCD-008

APRIL 19, 2021

STORY CONSTRUCTION
2810 WAKEFIELD CIRCLE
AMES, IA 50010

Attn: RICHARD VAN

Re: BONDURANT COMMUNITY LIBRARY – BID PACKAGE 06-1.

Richard,

The following is the cost for CCD-008. This pertains to the following:

- **Additional Temporary Wall.**

This will be an additional cost of \$967.73.

Very truly yours,

R. H. GRABAU CONSTRUCTION, INC.

Kevin S Porter

Date: 4-19-21



STORY CONSTRUCTION CO.
Ames, Iowa

WORK ORDER

PROJECT: Bondurant Library

WORK ORDER NO.: 001

DATE: 4-1-2021

Story Job No.: 20409

Work Performed For: _____

Contact: _____

DESCRIPTION OF WORK:
- Extended temp wall to south

LABOR:	Personnel	Cost Code	Reg. Hrs.	O.T. Hrs.
		<u>Bryan Parker</u>		<u>1 1/2 hrs</u>

EQUIPMENT:	Description	Hrs.

SMALL TOOLS:	Description	Hrs.

MATERIALS:	Description	Qty.

REMARKS:

Verified by: [Signature]
Story Construction

Submitted by: _____

STORY CONSTRUCTION CO.
Ames, Iowa

WORK ORDER

PROJECT: Bondurant Library

WORK ORDER NO.: 003

DATE: 4-5-2021

Story Job No.: 20409

Work Performed For: _____

Contact: _____

DESCRIPTION OF WORK:
extend temp wall; top out w/ plywood and insulate

LABOR:	Personnel	Cost Code	Reg. Hrs.	O.T. Hrs.
		<u>Bryon Porter</u>		<u>2 1/2</u>

EQUIPMENT:	Description	Hrs.

SMALL TOOLS:	Description	Hrs.

MATERIALS:	Description	Qty.

REMARKS:

Verified by: [Signature]
Story Construction

Submitted by: _____

cc: Field / Office

STORY CONSTRUCTION CO.
Ames, Iowa

WORK ORDER

PROJECT: Bondurant Library

WORK ORDER NO.: 002

DATE: 4-2-2021

Story Job No.: 20409

Work Performed For: _____

Contact: _____

DESCRIPTION OF WORK:
Extend keep wall to South; Framing and plywood

LABOR:	Personnel	Cost Code	Reg. Hrs.	O.T. Hrs.
		<u>Bryan Parker</u>		<u>7 hrs.</u>

EQUIPMENT:	Description	Hrs.

SMALL TOOLS:	Description	Hrs.

MATERIALS:	Description	Qty

REMARKS:

Verified by: [Signature]
Story Construction

Submitted by: _____

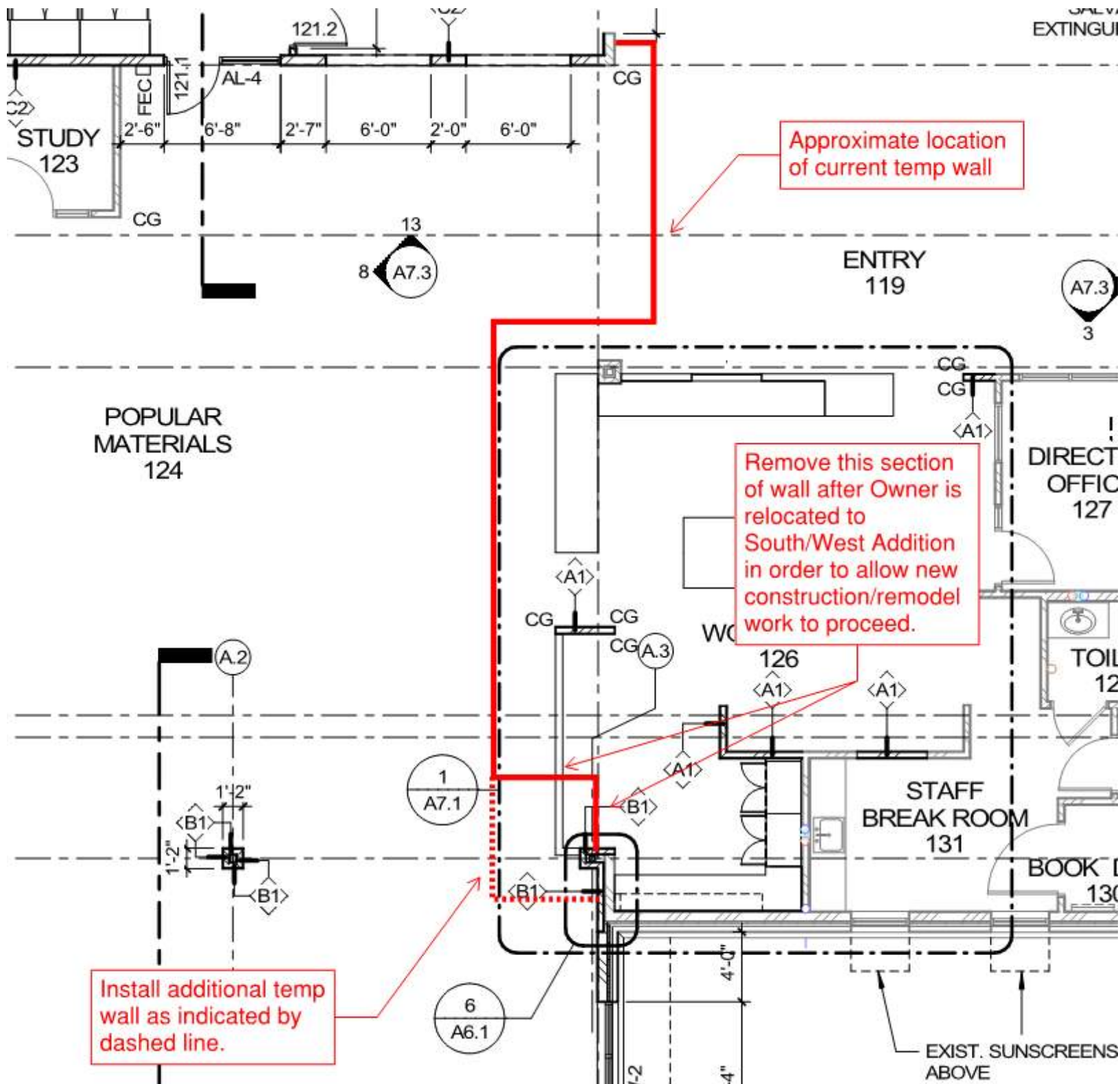

Approximate location of current temp wall

Remove this section of wall after Owner is relocated to South/West Addition in order to allow new construction/remodel work to proceed.

Install additional temp wall as indicated by dashed line.

EXTINGUI

STUDY 123

ENTRY 119

POPULAR MATERIALS 124

DIRECT OFFICE 127

TOILET 12

STAFF BREAK ROOM 131

BOOK ROOM 130

EXIST. SUNSCREENS ABOVE

2'-6" 6'-8" 2'-7" 6'-0" 2'-0" 6'-0"

13 A7.3 8

A7.3 3

A.2

1 A7.1

A1 A.3 CG CG

6 A6.1

WC

126 A1 A1

1-2 4"

4'-0"

4"

C2

121.1

AL-4

121.2

CG

CG

CG

CG

CG

CG

A1

A1

A1

A1

A1

B1

B1

B1

B1



CONSTRUCTION CHANGE DIRECTIVE NO. CCD-011

Date: April 15, 2021
To: BP 09-5 Ideal Floors
Subject: Non-Typical Floor Patching & Leveling Allowance Deduct
Re: **Bondurant Community Library Expansion**
City of Bondurant
Bondurant, Iowa

The following change in the contract document is to be priced for approval. Upon approval work is authorized to proceed accordingly. This change will be incorporated in a subsequent change order.

DESCRIPTION:

All changes that go to this allowance have or will be approved in a 'CCD' or 'CR' and executed in a 'CO' by District. Per the contract documents there was an allowance for Non-Typical Floor Patching and Leveling (01 2100).

Contractor:

BP 09-5 Ideal Floors	Allowance Deduct	(\$5,000.00)
----------------------	------------------	--------------

Issued by Story Construction Co.

Clint Jensen
Project Manager

Authorized by:

City of Bondurant

cc: Richard Van
Charlie Harris
Janie Bates



CONSTRUCTION CHANGE DIRECTIVE NO. CCD-013

Date: March 22, 2021
To: BP 22-1 Brockway Mechanical & Roofing
Subject: Temporary Heater Hookup & Thermostat Relocate
Re: **Bondurant Community Library Expansion**
City of Bondurant
Bondurant, Iowa

The following change in the contract document is to be priced for approval. Upon approval work is authorized to proceed accordingly. This change will be incorporated in a subsequent change order.

DESCRIPTION:

- 1) Provide pricing for labor and materials to hook up temporary heaters (provided by CM) to natural gas lines.
- 2) Provide pricing for labor and materials to relocate existing thermostat to inside of temporary enclosures (location determined by CM).

Contractor:

BP 22-1	Temp Heat Hookup & Thermostat Relocate	\$1,899.64
---------	--	------------

Issued by Story Construction Co.

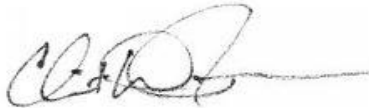

Clint Jensen
Project Manager

Authorized by:

City of Bondurant

cc: Richard Van
Charlie Harris
Janie Bates

Breakdown Sheet

Labor, Material, & Equipment Contractor's Proposal



Date: 4.8.21
 Title: CCD-013

Description: Connection of temp heaters to permanent natural gas service. (2.22.21 & 3.2.21)
Relocation of thermostat to inside of temp enclosure.(2/4/21)

Direct Employee Labor

Project Management @\$115.00		Hrs	\$	-
Plumber/Pipefitter @ \$85.00	5	Hrs	\$	425.00
Sheet Metal Worker @ \$82.00	14	Hrs	\$	1,148.00
CAD Tech @ \$58.50		Hrs		

Equipment

--	--

Material

Materials		\$	54.45

Total Labor, Material & Equipment		\$	1,627.45
15% Fee		\$	244.12
Total Labor, Material & Equipment & Fee		\$	1,871.57

Subcontractors

5% Fee	\$ -
Total Subcontractors & Fee	\$ -

Other Costs

Travel and Subsistence	\$ -
Materials and Equipment Not Incorporated	\$ -
Rentals	\$ -
Taxes	
Permits and License Fees	\$ -
Utilities, Fuel and Facilities at Site	\$ -
Incidental Expenses	\$ -
Bond and/or Insurance Provisions	\$ 28.07
15% Fee	
Total Other Costs & Fee	\$ 28.07

Grand Total	\$ 1,899.64
--------------------	--------------------

Price valid 30 days from date shown above



CONSTRUCTION CHANGE DIRECTIVE NO. CCD-014

Date: April 26, 2021
To: BP 06-1 RH Grabau Construction
Subject: Demolition Allowance Deduct
Re: **Bondurant Community Library Expansion**
City of Bondurant
Bondurant, Iowa

The following change in the contract document is to be priced for approval. Upon approval work is authorized to proceed accordingly. This change will be incorporated in a subsequent change order.

DESCRIPTION:

All changes that go to this allowance have or will be approved in a 'CCD' or 'CR' and executed in a 'CO' by District. Per the contract documents there was an allowance for Demolition (01 2100).

Contractor:

BP 06-1 Grabau	Allowance Deduct	(\$6,000.00)
----------------	------------------	--------------

Issued by Story Construction Co.

Clint Jensen
Project Manager

Authorized by:

City of Bondurant

cc: Richard Van
Charlie Harris
Janie Bates



CONSTRUCTION CHANGE DIRECTIVE NO. CCD-015

Date: April 26, 2021
To: BP 09-1 Hilsabeck Schacht Inc
Subject: Patching of Gypsum Board at MEP Penetrations Allowance Deduct
Re: **Bondurant Community Library Expansion**
City of Bondurant
Bondurant, Iowa

The following change in the contract document is to be priced for approval. Upon approval work is authorized to proceed accordingly. This change will be incorporated in a subsequent change order.

DESCRIPTION:

All changes that go to this allowance have or will be approved in a 'CCD' or 'CR' and executed in a 'CO' by District. Per the contract documents there was an allowance for Patching of Gypsum Board at MEP Penetrations (01 2100).

Contractor:

BP 09-1 H.S.I	Allowance Deduct	(\$6,000.00)
---------------	------------------	--------------

Issued by Story Construction Co.

Clint Jensen
Project Manager

Authorized by:

City of Bondurant

cc: Richard Van
Charlie Harris
Janie Bates